

# ROADTHUNDER®

# RTL10-44

## Wiring Configuration

La Configuración del alambrado, La Configuración del alambrado, Verdrahtende Konfiguration

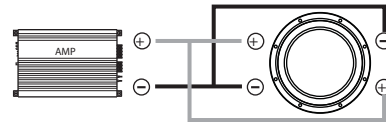

**With coils wired in parallel** (Con rollos alambro en la paralela, Avec les bobines télégraphiées dans l' analogie, Mit Windungen hat parallel verdrahtet):

A dual 4Ω speaker will represent a 2Ω load. (Un doble 4Ω orador representará una carga 2Ω, Un double 4Ω haut-parleur représentera un 2Ω chargent, Ein doppelte 4Ω Sprecher beladen eine 2Ω wird vertreten)

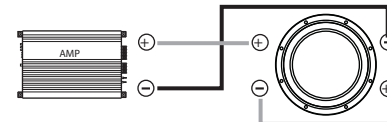

**With coils wired in series** (Con rollos alambro en la serie, Avec les bobines télégraphiées dans le feuilletton, Mit Windungen, die in serie verdrahtet werden):

A dual 4Ω speaker will represent a 8Ω load. (Un doble 4Ω orador representará una carga 8Ω, Un double 4Ω haut-parleur représentera un 8Ω chargent, Ein doppelte 4Ω Sprecher beladen eine 8Ω wird vertreten)

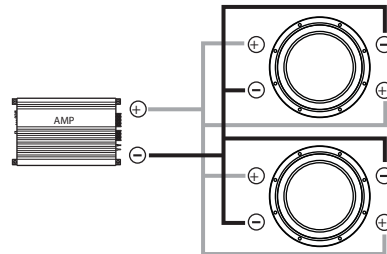

**With coils and speakers wired in parallel** (Con rollos y oradores alambro en la paralela, Avec les bobines et les haut-parleurs a télégraphiées dans l' analogie, Mit Windungen und Sprecher haben parallel verdrahtet):

Two dual 4Ω speaker will represent a 1Ω load. (Dos doble 4Ω orador representará una carga 1Ω, Deux double 4Ω haut-parleur représentera un 1Ω chargent, Zwei doppelte 4Ω Sprecher wird eine 1Ω last vertreten)

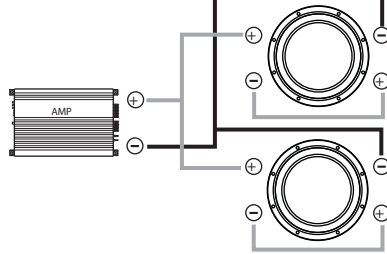

**With coils wired in series and speakers wired in parallel** (Con rollos y alambro en la serie y oradores alambro en la paralela, Avec les bobines télégraphiées dans le feuilletton et les haut-parleurs a analogie, Mit Windungen, die in serie verdrahtet werden, und Sprecher haben parallel verdrahtet):

Two dual 4Ω speaker will represent a 4Ω load. (Dos doble 4Ω orador representará una carga 4Ω, Deux double 4Ω haut-parleur représentera un 4Ω chargent, Zwei doppelte 4Ω Sprecher wird eine 4Ω last vertreten)

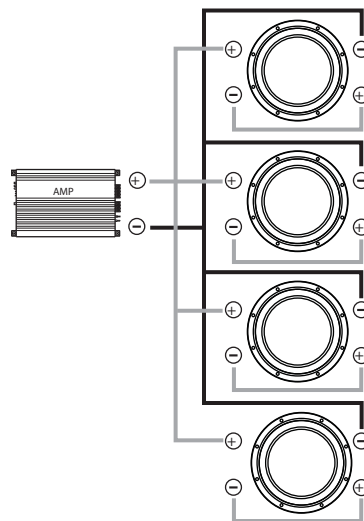

**With coils wired in series and speakers wired in parallel** (Con rollos alambro en la serie y oradores alambro en paralela, Avec les bobines télégraphiées dans le feuilletton et les haut-parleurs a télégraphié dans l' analogie, Mit Windungen die in serie verdrahtet werden, und Sprecher haben parallel verdrahtet):

Four dual 4Ω speaker will represent a 2Ω load. (Cuatro doble 4Ω orador representará un 2Ω carga, Quatre double 4Ω haut-parleur représentera un 2Ω chargent, Vier doppelter 4Ω Sprecher beladen eine 2Ω wird vertreten)

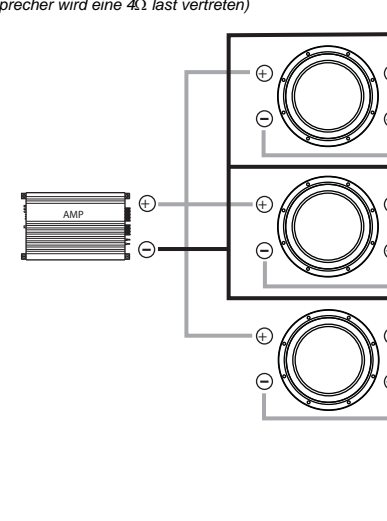

**With coils wired in series and speakers wired in parallel** (Con rollos alambro en la serie y oradores alambro en paralela, Avec les bobines télégraphiées dans le feuilletton et les haut-parleurs a télégraphié dans l' analogie, Mit Windungen, die in serie verdrahtet werden, und Sprecher haben parallel verdrahtet):

Three dual 4Ω speaker will represent a 2.7Ω load. (Tres doble 4Ω orador representará una carga 2.7Ω, Trois double 4Ω haut-parleur représentera un 2.7Ω chargent, Drei doppelter 4Ω Sprecher wird eine 2.7Ω last vertreten)

MTX products purchased in the USA from an authorized MTX dealer are guaranteed against defects in material and workmanship for a period of 1 year, the warranty period begins the day the product is purchased by the end user. This warranty is limited to the original retail purchaser of the product. Product found to be defective during that period will be repaired or replaced by MTX at no charge. This warranty is void if it is determined that unauthorized parties have attempted repairs or alterations of any nature. Warranty does not extend to cosmetics or finish. Before presuming a defect is present in the product, be certain that all related equipment and wiring is functioning properly. MTX disclaims any liability for other incurred damages resulting from product defects. Any expense in the removal or reinstallation of products are not covered by this warranty. MTX's total liability will not exceed the purchase price of the product. If a defects is present, your authorized MTX dealer may be able to effect repairs.

Proof of purchase is required when requesting service, so please retain your sales receipt, and take a moment to register your product on line at MTX.com. Also, a Return Authorization number (RA) is required before shipping product back to MTX, call 1-800-556-2888 or 1-608-328-5560 for speaker RA's.

# MTX AUDIO

# ROADTHUNDER®

# RTL10-44

## Parameters

Los parámetros, Paramètres, Parameter

**Fs:** 32.4 Hz  
**Qms:** 5.516  
**Cms:** 0.202 mm/N  
**Mms:** 120 g  
**Rms:** 4.422 kg/s  
**Vas:** 1.328 ft<sup>3</sup> (37.6 liters)  
**Xmax:** 0.37 in (9.4 mm)  
**D:** 8.46 in (214.8 mm)  
**Sd:** 56.3 in<sup>2</sup> (363.03 cm<sup>2</sup>)  
**Vd:** 20.831 in<sup>3</sup> (0.341 liters)  
**Qes:** 0.823  
**Re:** 2.0 Ω  
**Bl:** 7.75 Tm  
**Prms:** 200 Watts  
**Qts:** 0.716  
**η<sub>o</sub>:** 0.149%  
**SPL<sub>o</sub>:** 84 dB  
**SPL 2.83V/1m:** 90 dB

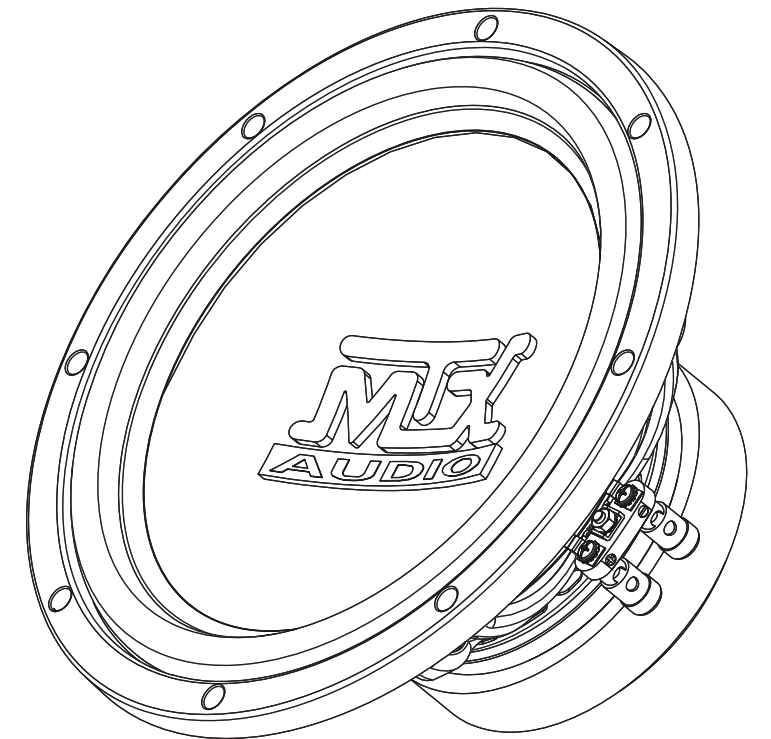

## Specifications

Las especificaciones, Specifications, Spezifikationen

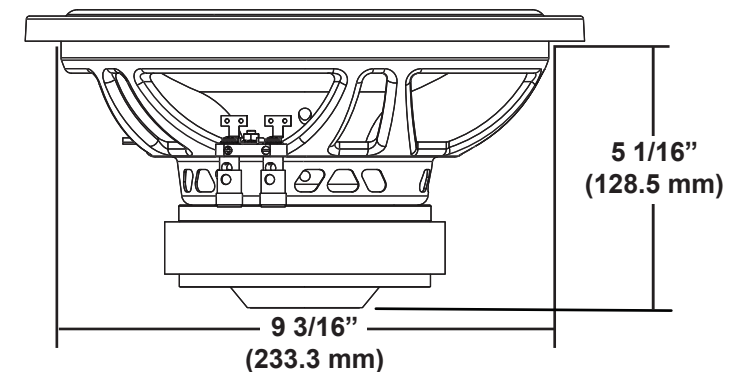
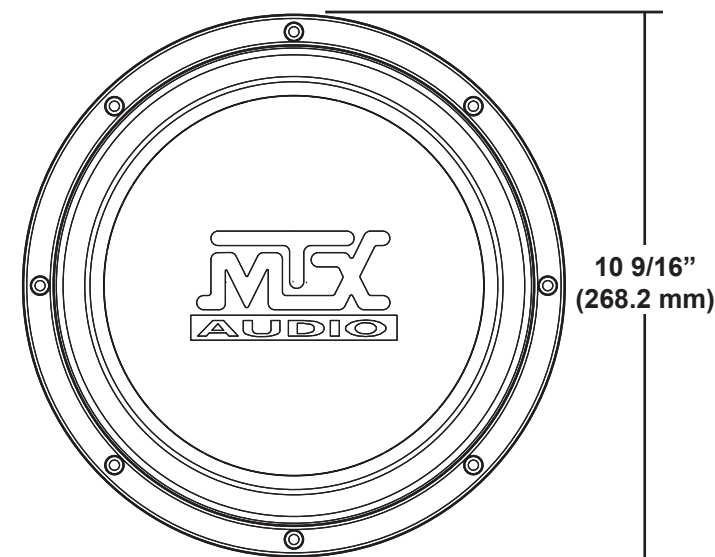

## Recommended Power Rating of 100 - 200 Watts RMS

La Potencia nominal recomendada, Le Pouvoir recommandé Evaluant, Empfohlene Kraft Einzuschätze

# ROADTHUNDER®

## Sealed Enclosure

*El Cerco sellado, Cloture scellée, Abgedichtete Einschließung*

For the best possible sound quality where space is a premium, MTX recommends using a sealed enclosure. For excellent sound quality with increased output compared to sealed enclosures (3dB or more), MTX recommends using a vented enclosure. All recommended enclosures have been designed and thoroughly tested by MTX.

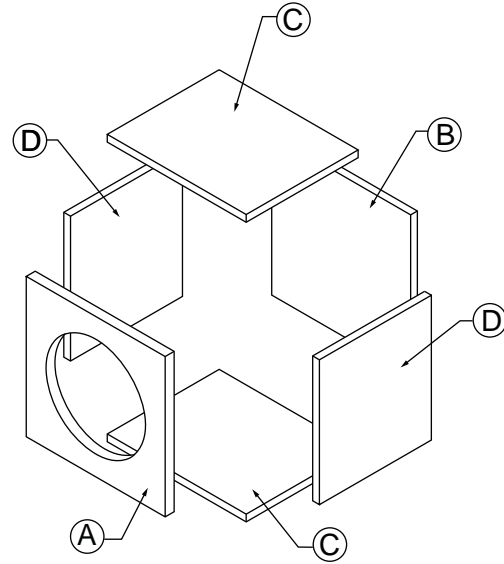
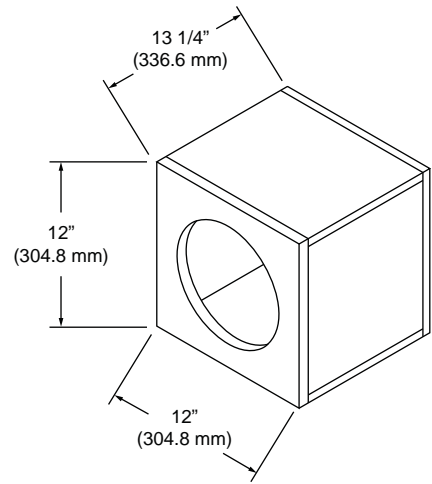

Net Internal Volume: 0.75 ft<sup>3</sup>

## Parts List

*La Lisat de partes, Liste de parties, Ersatzteilliste*

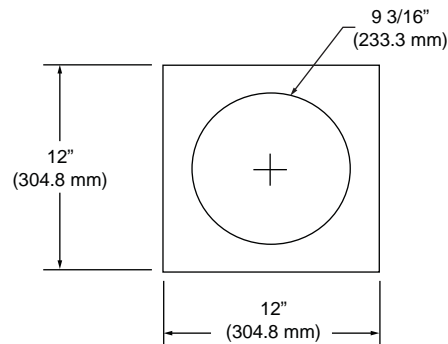

[A] - 3/4" (19 mm) MDF

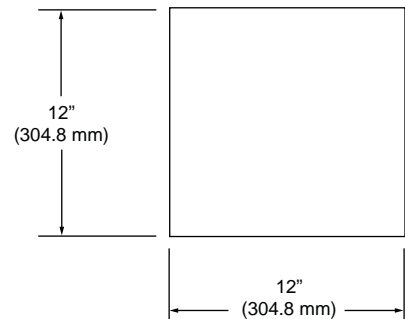

[B] - 3/4" (19 mm) MDF

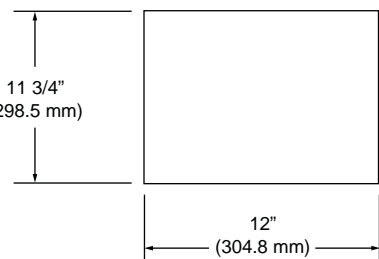

[C] - 3/4" (19 mm) MDF

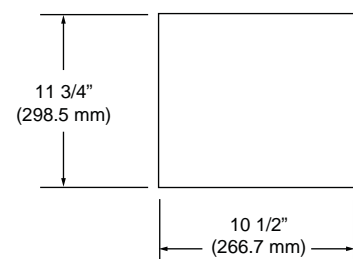

[D] - 3/4" (19 mm) MDF

# RTL10-44

# ROADTHUNDER®

## Vented Enclosure

*Descargar Cerco, Clôtüre donnere vent, Vented Einschließung*

For the best possible sound quality where space is a premium, MTX recommends using a sealed enclosure. For excellent sound quality with increased output compared to sealed enclosures (3dB or more), MTX recommends using a vented enclosure. All recommended enclosures have been designed and thoroughly tested by MTX.

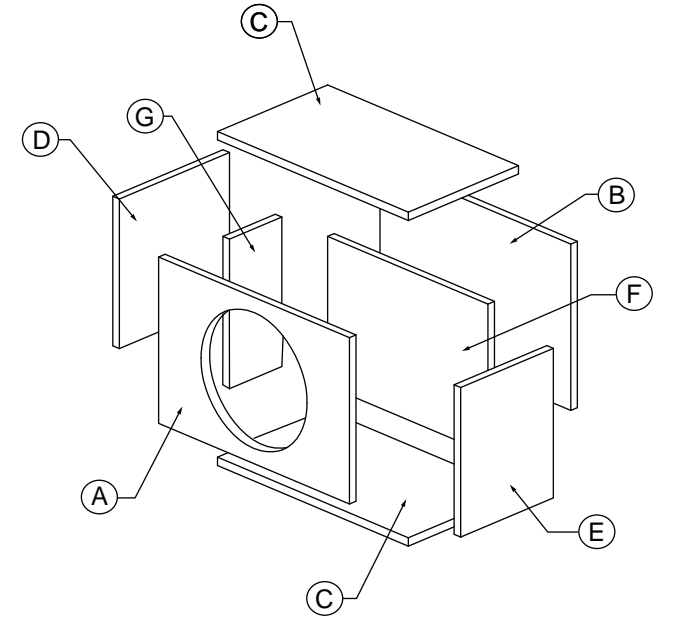
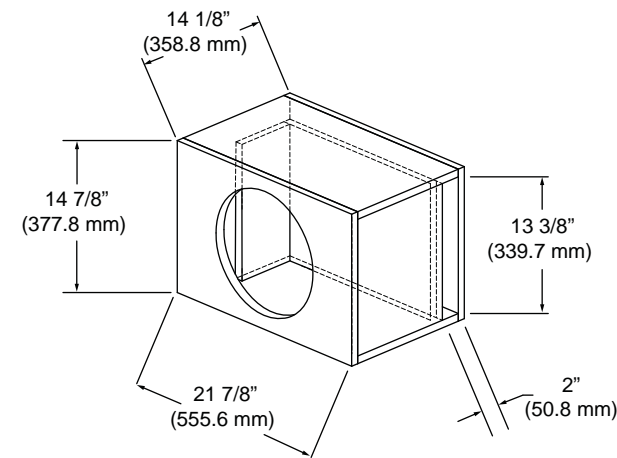

Net Internal Volume: 2.00 ft<sup>3</sup>

## Parts List

*La Lisat de partes, Liste de parties, Ersatzteilliste*

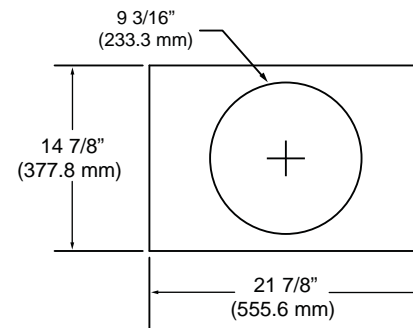

[A] - 3/4" (19 mm) MDF

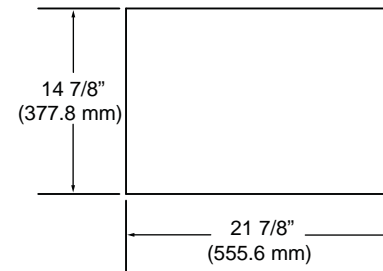

[B] - 3/4" (19 mm) MDF

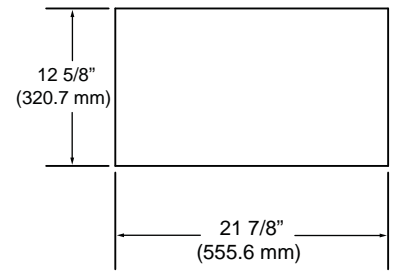

[C] - 3/4" (19 mm) MDF

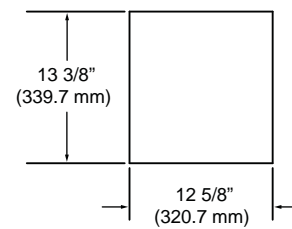

[D] - 3/4" (19 mm) MDF

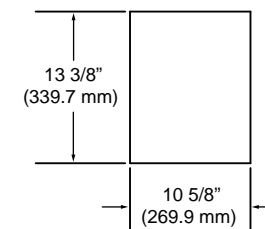

[E] - 3/4" (19 mm) MDF

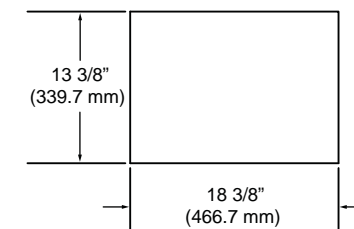

[F] - 3/4" (19 mm) MDF

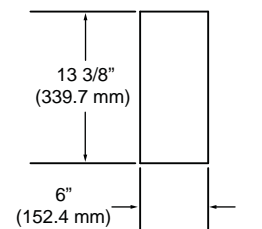

[G] - 3/4" (19 mm) MDF