

MVXA Series Specifications

Size: 1-3/4"H x 9.5"D x 19"W
(34 x 241 x 482mm)
One Rack Unit

Weight: 7 lbs (3.2Kg)

Supply Voltage: 15 VAC power supply
(included)

Channels: MVXA-2008 is 8 channels
MVXA-2016 is 16 channels

Total Harmonic Dist.: <1%

Floor Noise: 76dB

Internal Speaker: 3 Watts / 8 ohm

Power Consumption: 6 Watts

Frequency Response: 35 Hz - 20 kHz

Channel Turn-On Delay: 1 Second

INPUTS:

Available "0dB" References:

Line Level (1 Vrms),
25 Vrms, 70 Vrms,
100 Vrms

LED Display:

Accuracy: 1.5 dB

Sensitivity: -30 dB to +3 dB

Monitoring Range: 0.0316 Vrms
(-30 dBV) to 200 Vrms

Dynamics: Bottom 10: VU Response,
Green (-30 dB to -2 dB)
Top 2: Peak Response,
Red (0 dB to +3 dB)

Audio Outputs:

Line level : Terminals on back

3 Watt amplifier (5 Watt peak) into:

- Internal speaker
- Headphone jack
- External speaker output
(4Ω or 8Ω) terminals
on back

Rear View

(Terminal Cover Not Shown)

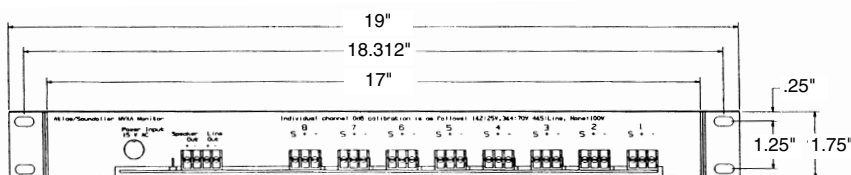

Top View

(Terminal Cover Not Shown)

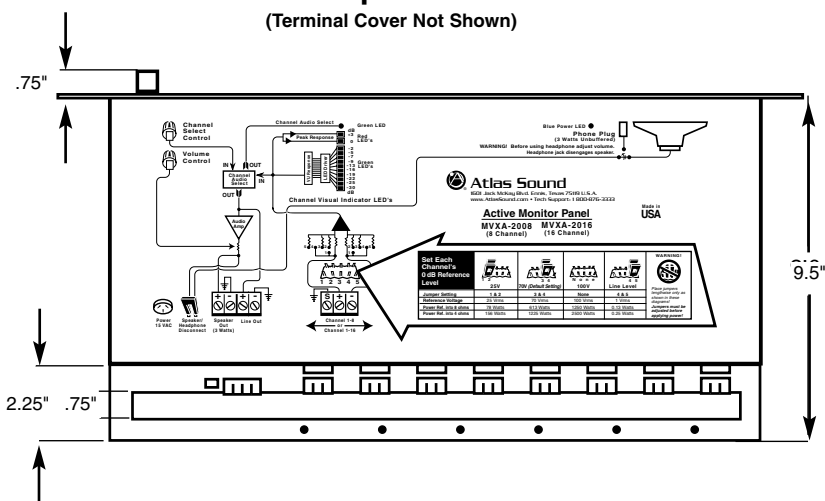

Front View

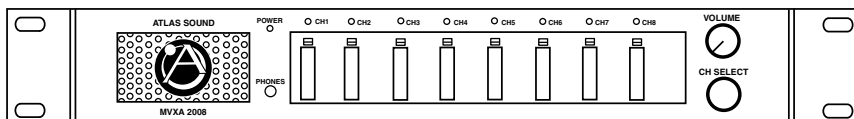

Side View

(Terminal Cover Shown Detached)

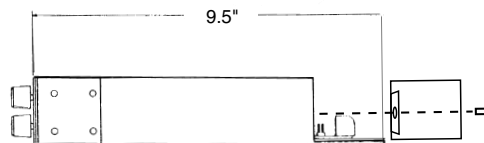

Atlas-Sound Technical Support 1-800-876-3333
www.atlassound.com

Specifications subject to change without notice



1601 JACK MCKAY BLVD. / ENNIS, TEXAS 75119 U.S.A. / TELEPHONE: (800) 876-3333 / FAX (800) 765-3435



MVXA Series Multi-Channel Amplified Monitor Panel Users Manual

MVXA-2008
MVXA-2016



Accurate speaker and line level monitoring in a single rack unit!

- 8 or 16-channel audible and visual monitoring
- Sophisticated single rack-unit design (1RU)
- Selectable input references of 1Vrms, 25Vrms, 70Vrms, or 100Vrms
- Accurate visual monitoring of all channels simultaneously
- LED's display green or red for easy identification of referenced signal levels
- Internal speaker, headphone jack, line level output, and speaker output
- Multiple patents pending

Specifications subject to change without notice



1601 JACK MCKAY BLVD. / ENNIS, TEXAS 75119 U.S.A. / TELEPHONE: (800) 876-3333 / FAX (800) 765-3435

Enhanced benefits include:

Compact electronic design achieves 8 or 16 channel
audible & visual monitoring in a single rack space!

Each meter can be individually referenced to Line Level (1Vrms), 25Vrms, 70Vrms, or 100Vrms input to collectively
monitor multiple signal types in any combination

An internal speaker, headphone jack, line level output, and an external speaker output are available for
versatile audio monitoring of each channel

A 12 segment LED meter for each channel provides accurate
visual monitoring of all channels simultaneously
plus...

Green LED's indicate VU ballistics of -30 dB to -2 dB, Red LED's identify when signals peak at 0 dB to +3 dB relative to reference level for
easy identification of critical signal levels

Visual Monitoring

The MVXA Series efficiently monitors from -30 dBV (line level reference) to 200Vrms (100Vrms reference). Units are capable of monitoring any combination of 25V, 70V, 100V, or line level signal inputs. (Signal type of each channel is individually set using adjustable jumpers.) All channels can be visually monitored simultaneously as each signal has its own twelve segment LED bargraph that provides 33 dB of resolution. The bottom ten LEDs are green and have VU ballistic response for -30 dB to -2 dB. The top two red LEDs have peak response characteristics for 0 dB to +3 dB above reference level to provide easy identification of critical signal levels.

Audio Monitoring

Audio monitoring methods include: an internal speaker, a headphone jack, a 3 watt speaker output for connection to an external speaker, and a line level output for connection to an amplifier.

Isolation

Both MVXA models feature Atlas-Soundolier's exclusive CerAmp™ technology (patent pending) to isolate noise from the input channels. Our CerAmp™ design utilizes ceramic capacitors and an op-amp to achieve high input impedance isolation without transformers to reduce distortion, hum, and noise.

Mounting Flexibility

The compact design of the MVXA is ideally suited for shelf, rack, or wall mounting. To facilitate application flexibility, rack mount brackets may be installed in three different ways for standard rack or wall mount applications including single and side-by-side wall orientation.

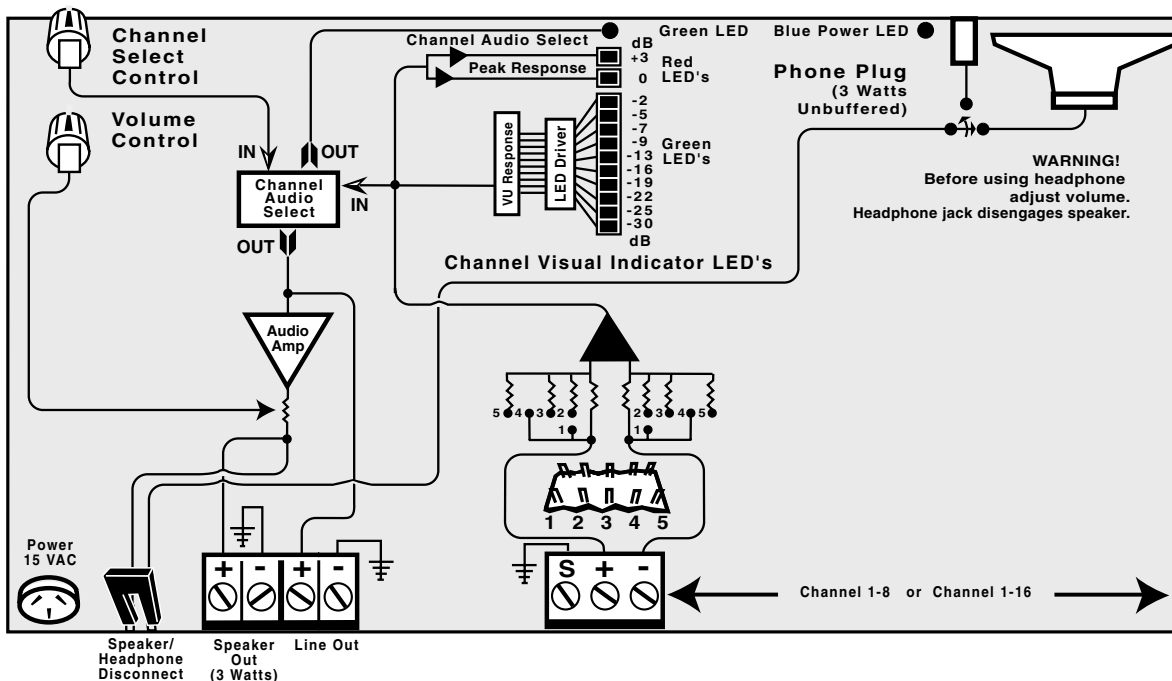







Figure 1 Functional Diagram (as found on top panel plate)

MVXA Series *Fast Install Overview*

- 1 Remove Rear Panel Cover and set jumpers for each input to desired reference level (25V, 70V, 100V, or line level).

Each channel is independent so that signals of different types can be monitored on the same unit.

Set Each Channel's 0 dB Reference Level	 25V	 70V (Default Setting)	 None	 Line Level	WARNING!  Place jumpers lengthwise only as shown in these diagrams! Jumpers must be adjusted before applying power!
Jumper Setting	1 & 2	3 & 4	None	4 & 5	
Reference Voltage	25 Vrms	70 Vrms	100 Vrms	1 Vrms	
Power Ref. into 8 ohms	78 Watts	613 Watts	1250 Watts	0.13 Watts	
Power Ref. into 4 ohms	156 Watts	1225 Watts	2500 Watts	0.25 Watts	

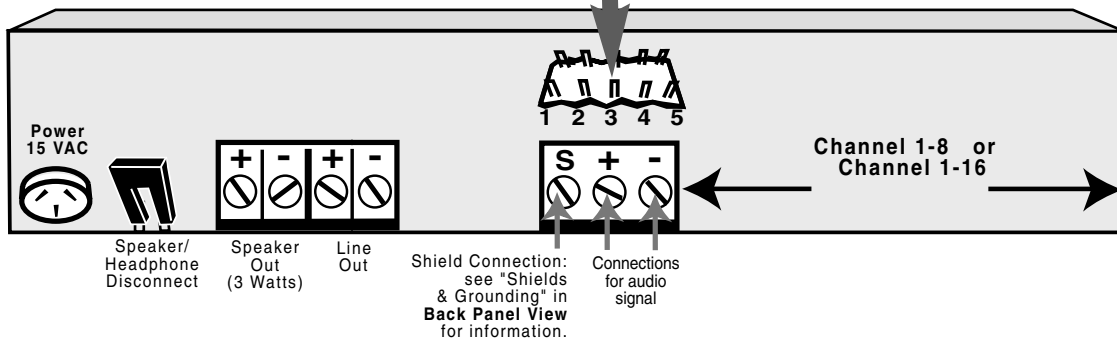

- 2 Rack mount (if desired).

Assure proper "Earth Ground"- see paragraph *Shields and Grounding* located in *Back Panel View* for detailed information.

- 3 Connect each piece of equipment to be monitored to a separate ⊕ & ⊖ input terminal (channel 1-8 or 1-16).

- 4 Determine desired audio monitoring method and action.

METHOD	ACTION
A. Internal Speaker	No Action Required.
B. Headphone Jack	Plug in headphone. This automatically bypasses the internal speaker.
C. External Speaker	Connect external speaker to ⊕ and ⊖ <i>speaker out</i> terminals. If listening to both internal and external speakers is desired; keep the speaker/headphone disconnect jumper in the "on" position. If only the external speaker is desired; move the speaker/headphone disconnect jumper to "off".
D. External Line Level	Connect line level source to ⊕ and ⊖ <i>line level out</i> terminals. If listening to both the internal speaker and line level device is desired; keep the speaker/headphone disconnect jumper in the "on" position. If only the line level device is desired, move the speaker/headphone disconnect jumper to "off".

- 5 Perform any desired wire management and labeling functions.

- 6 Connect the power supply (included) to the MVXA.

- 7 Attach rear cover.

- 8 Plug the power supply into a 110/120 VAC outlet.

MVXA Series Front Panel View

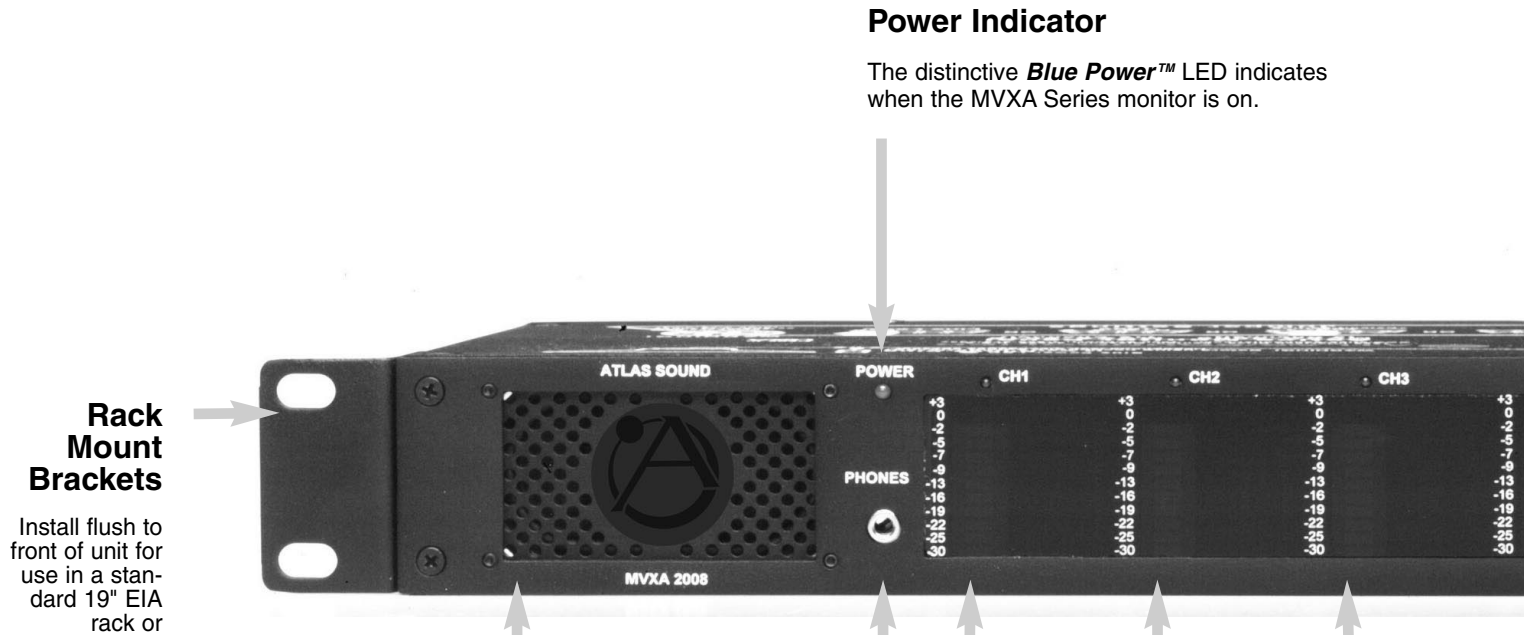

Rack Mount Brackets

Install flush to front of unit for use in a standard 19" EIA rack or

Power Indicator

The distinctive **Blue Power™** LED indicates when the MVXA Series monitor is on.

Output Amplifier

The MVXA Series uses a 3 watt amplifier to drive the internal speaker, headphone jack, and/or an external speaker.

Headphone Monitoring

When the mini headphone jack is utilized, the internal speaker is automatically bypassed.

Caution: Turn volume level completely down before plugging in headphones. High sound pressure levels are possible.

Internal Speaker

The internal speaker provides built-in audio monitoring capability. It may be used in conjunction with other monitoring methods or bypassed (see examples).

Examples:

1. Headphones may be used to monitor the audio signal. When headphones are connected to the mini headphone jack; the internal speaker is bypassed.
2. An external speaker may be connected to the speaker out terminals for local or remote monitoring. When an external speaker is connected, both internal and external speakers will be active. To bypass the internal speaker, the speaker/headphone disconnect jumper may be moved to the "off" position. **NOTE:** This also bypasses the headphone jack.
3. An external line level device may be connected to the line out terminals. *When connected, both the internal speaker and the line level device will be active.* To bypass the internal speaker, the speaker/headphone disconnect jumper may be moved to the "off" position. **NOTE:** this will also bypass the headphone jack. *(The line level device is not affected by the unit's volume control).*

Top Panel Functional Diagram

For installation convenience, the MVXA includes a functional operation and jumper setting diagram silk-screened on the top of the unit.

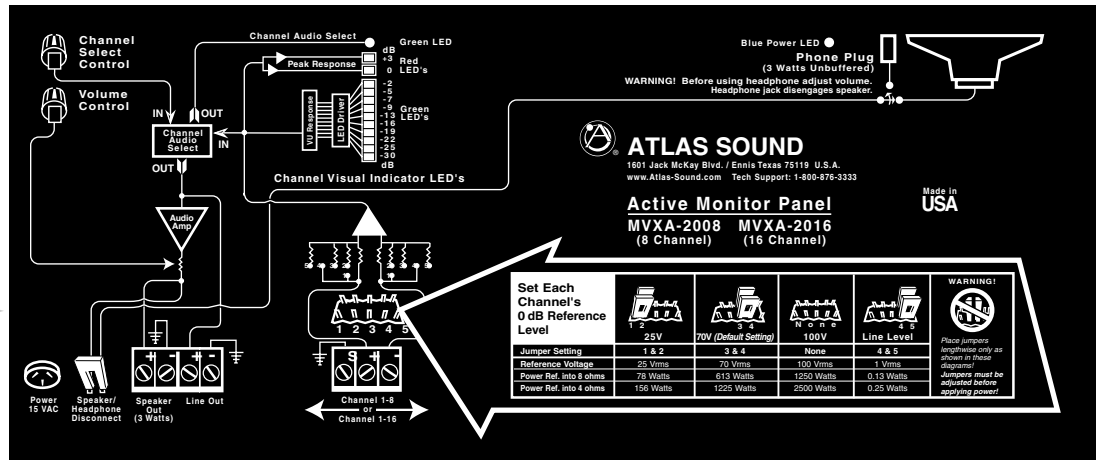

Volume Knob

Adjusts the output volume to the internal speaker, headphone jack, and/or external speaker. (The external line level output is not affected by this knob).

NOTE: When using headphones for audible monitoring, make sure you adjust completely down (counter clock wise) and then adjust volume up accordingly.

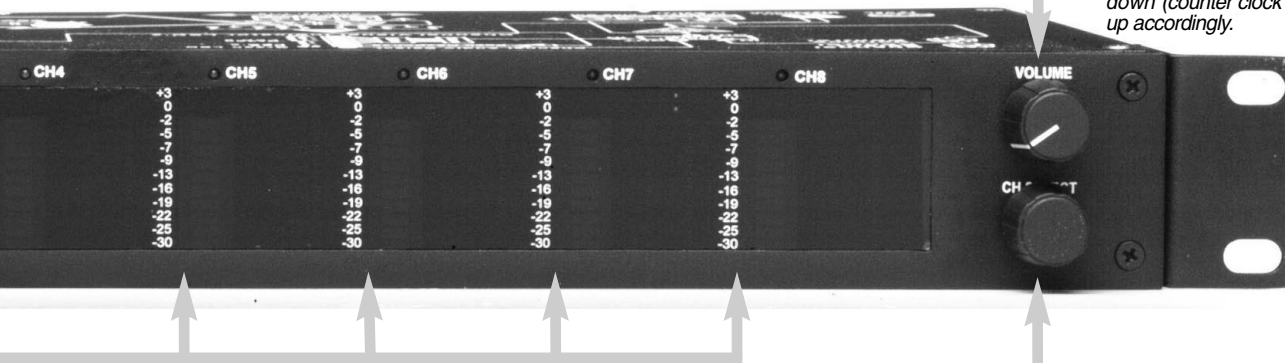

Visual Monitoring LEDs

Monitor panels have eight (MVXA-2008) or sixteen (MVXA-2016) bargraph displays; one for each channel. Each display uses twelve, high-quality and oversized LEDs to provide clear identification and easy readability from a distance. The meter's dynamic range is from -30 dB to +3 dB.

The bottom ten LEDs are green and have VU ballistics similar to a typical analog meter. Monitoring the range from -30 dB to -2 dB.

The top two LEDs are red to indicate peak response. They correspond to 0 dB and +3 dB to indicate short input levels that are above the specified reference level. This provides immediate visual warning if signal peaks are above the reference level.

Audio Monitoring Channel Selector

Audio monitoring of each channel is accomplished using a rotary knob that selects one channel at a time. The LED for the selected channel (located above the bargraph) will light to indicate which channel is being monitored. The audio path from input to output is fully analog, providing signal integrity to the internal speaker; headphone jack, external speaker, and/or line level device.

Stereo Monitoring

Visual monitoring of stereo signals may be accomplished by simply connecting left and right signal connections to separate channels (ex: left to channel 1, right to channel 2).

NOTE: If simultaneous audible monitoring of stereo signals is required, two MVXA units are necessary; one for the left signal and the other for the right signal.

MVXA Series Back Panel View (Rear Panel Cover Removed)

Shields and Grounding

The MVXA requires a solid "earth ground" connection. The unit itself is internally grounded from the circuit board to the chassis and should receive a good "earth ground" under most mounting conditions. If the unit is not rack mounted or the powder-coat paint is interfering with the case grounding, then one of the "S" ground screw terminals should be taken directly to earth ground.

Grounding is by nature complex and often requires a variety of options. If the direct connection to earth ground is not desired. Contact technical support on how to properly break the shield to earth ground connection.

Speaker / Headphone Disconnect Jumper

When an external speaker or line level device is connected, the internal speaker and headphone jack continue to operate. If this is not desired, the speaker/headphone disconnect jumper may be moved to the off position to bypass the internal speaker and headphone jack. See *Internal Speaker Examples* on the **Front Panel View**.

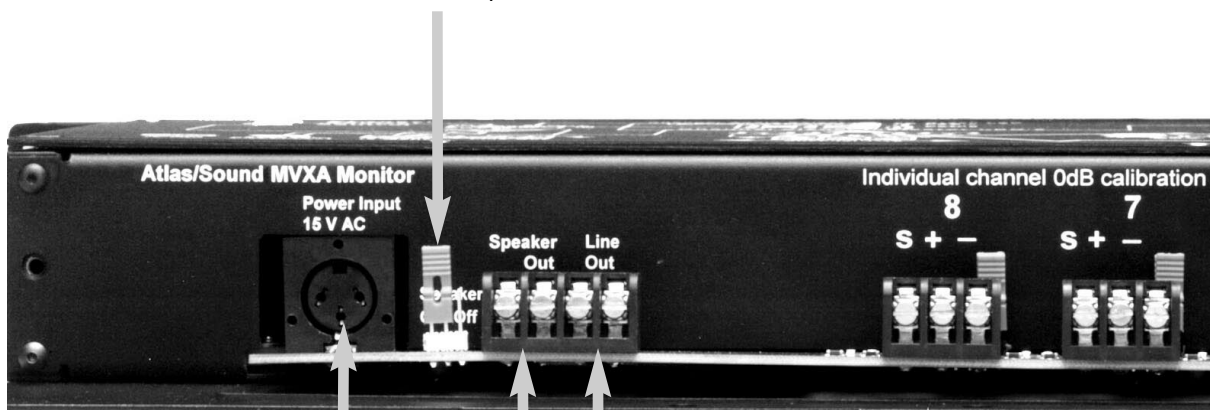

Power Input

The MVXA Series requires a 15-20 Volt AC or DC power supply. A 15 VAC table top supply is included with the unit. The provided power supply may only be connected to a 110-120 VAC power receptacle.

Speaker Out Terminals

An external speaker may be connected to the speaker out terminals for local or remote monitoring. The external speaker may be operated with or without the internal speaker (see internal speaker examples on the **Front Panel Tour**). The output level is adjusted by the front volume control. The external speaker level output is rated at 3 watts into 8 ohms with a minimum 4 ohm load.

Line Level Out Terminals

The MVXA includes a line level output. The output of the line level device is not affected by the volume control.

Lacing Rail

The MVXA's bottom panel includes many wire management features. Holes are located along the back of the panel for tie wrapping. These holes are spaced 2" apart to allow the use of readily available hardware handles or lacing bars. There is also a 3/4" opening along the entire length of the bottom panel for wire access. The rear panel cover is also equipped with knockouts on either end for wire management.

Terminal Inputs

Each of the unit's eight or sixteen channel inputs is independent allowing audio and visual monitoring of any combination of 25V, 70V, 100V, and line level circuits. Each channel provides level indication and is selectable to a "0" dB reference through easily accessible jumpers. The available references are shown in Figure 2.

Since each channel is independent, the MVXA can monitor multiple signal types. For example: Ch1 could be a line level, Ch2 the 70V output from an amplifier, Ch3 a line level from another source, etc.

The default setting for all channels is 70V.

Rear Panel Cover (not shown)

The protective rear panel cover should be placed on the unit after wiring to avoid accidental contact with rear terminals. The cover has knockouts on each end to help with wire management.

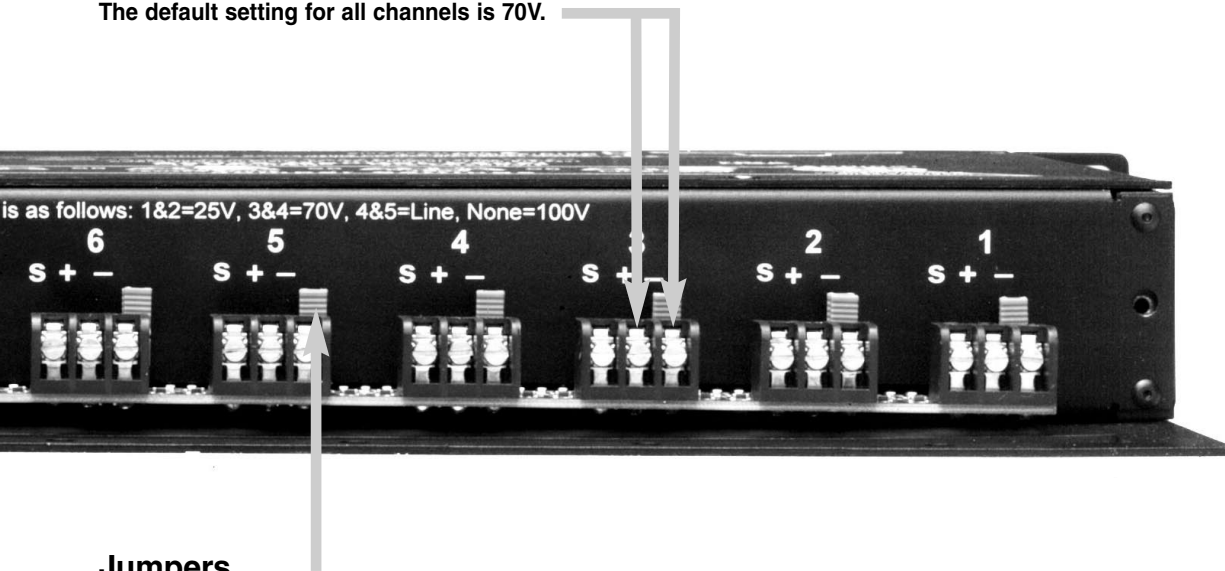

Jumpers

Jumpers are to be adjusted **prior** to applying power to the MVXA monitor panel. Jumpers have an extended tab for ease of placement.

Always put the jumpers on the same numbers. EX: 1 & 2, 3 & 4, or 4 & 5. No jumpers are used for the 100 volt input setting.





Set Each channel's 0 dB Reference Level	 25V	 70V (Default Setting)	 None 100V	 Line Level	WARNING!  Place jumpers lengthwise only as shown in these diagrams! Jumpers must be adjusted before applying power!
Jumper Setting	1 & 2	3 & 4	None	4 & 5	
Reference Voltage	25 Vrms	70 Vrms	100 Vrms	1 Vrms	
Power Ref. into 8 ohms	78 Watts	613 Watts	1250 Watts	0.13 Watts	
Power Ref. into 4 ohms	156 Watts	1225 Watts	2500 Watts	0.25 Watts	

Figure 2

Choose jumper settings to match desired 0 dB reference (25V, 70V, 100V, or line level).