

"I totally abuse my mic stand during every performance."

Atlas mic stands hold up night after night and never fall short"

*-Dane Adrian, of squint
www.squint.com*

Microphone Stands



Atlas Sound mic stands have been the preferred choice for over 70 years and have been used by professional musicians from legendary performers including the Beatles and Elvis to today's hottest bands like Gym Class Heros, Fall Out Boy, and The Academy Is...

PA systems, school auditoriums, convention and events centers, and meeting rooms are also common places to experience the most trusted microphone stands and accessories available because they are synonymous with durability and quality. The world recognized product line includes cast-base and tripod style floor stands, desk, and studio boom stands; boom attachments; loudspeaker/equipment stands; and over 40 adapters and fittings. The unique selection offers the professional musician, performer, educator, and lecturer great flexibility in choosing models that satisfy unique application, performance, and budget requirements. Classic styling in mirrored chrome or non-reflective ebony epoxy (perfect for video application) combine with the famous Atlas Sound wear-proof clutches to provide attractive, durable, and reliable service for all types of communication and entertainment applications.



Tube Extension 35" - 63"
Base: 9lb, 10" Cast Iron

MS-10C

Tube Extension 35" - 63"
Base: 9lb, 10" Round Cast Iron

MS-10CE

Tube Extension 35" - 63"
Base: 9lb, 12" Round Cast Iron

MS-12C

Tube Extension 35" - 63"
Base: 8lb, 12" Round Cast Iron

MS-43E

All-Purpose Floor Stands

MS-10C / MS-10CE. cost-efficient assemblies are the most frequently purchased stand throughout the world for dependable performance in music, entertainment, business, education, and social functions. MS-10C includes chrome finished tube and circular cast iron base. MS-10CE is supplied with ebony finished tube and circular cast iron base.

Professional Full-Height Stands

MS-12C / MS-12CE. All-purpose stands feature wearproof clutch for quick height adjustment and a high-stability, low profile cast base. MS-12C consists of chromed tube and ebony base. MS-12CE features ebony finished tube and base.

Fully Adjustable Three-Section Stands

MS43E. Versatile stand adjusts from 25" to 65" to meet the needs of seated and standing instrumentalists and performers. Model includes three-section ebony tube assembly with two wearproof clutches for optimum vertical height adjustment and high stability. All models feature a low-profile cast iron base finished in ebony. The MS43E base is 12" in diameter and weighs 8 lbs.



Step 1



Step 2



Step 3

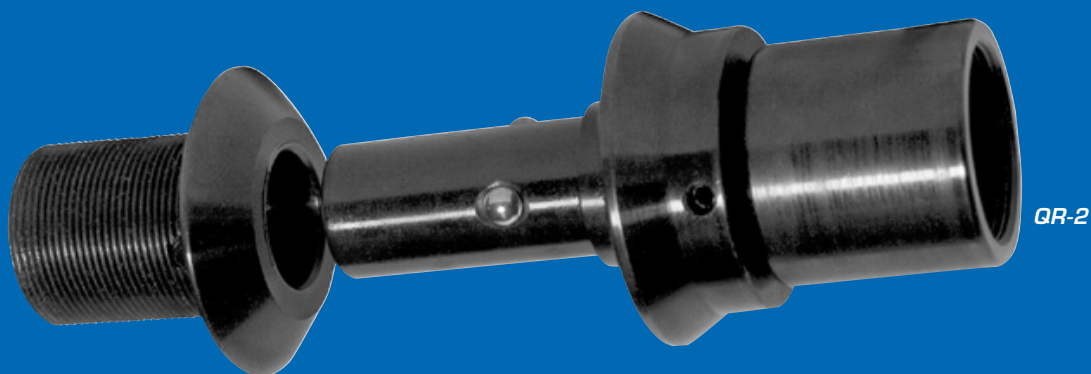

QR2 – Quick Release Tube Adapter

The two piece design uses a unique ball bearing interconnect designed to save set-up and tear down time in touring applications. For installation the QR-2 assembly is threaded between the 7/8" tube and base of the mic stand (MS10C, MS10CE, MS12C, and MS12CE). After the show, the technician simply steps on the low profile outer release ring of QR-2 allowing the entire upper tube assembly to be separated from the base saving the time consuming operation of unscrewing the base / tube for storage.

The QR-2 is constructed of durable machined steel and finished in black chromate to blend in perfectly with the mic stand base top surface for an unobtrusive onstage look.

A microphone stand spends the majority of its time in the spotlight but still the importance of its quality and easy to use is arguable the most overlooked equipment need. for importances. While they play no direct role in the way a system might sound they can drastically alter a performance. A mic stand that falls from its necessary height, or an impossible to position drum mic, or a stand that can't handle the abuse a rock and roller can throw at them are unacceptable. Atlas stands are fully tested and are regularly relied upon to deliver the duriability only Atlas can.

Atlas Advantage

- Steel tubing is finished in a choice of mirrored chrome or non-reflective ebony
- Anti-vibration cap absorbs incidental vibrations and sounds
- Lock-nut ring securely positions tubing to base
- Atlas Sound stands are threaded $\frac{5}{8}$ "-27 and include a lock-nut ring for versatile positioning of accessories
- Famous Atlas Sound clutch won't slip under pressure
- Bases are high-stability cast metal equipped with shock absorbing rubber pads

Atlas Sound floor stands are made to last! Quality design and over 75 years worth of performances — on stage and off — offer proven reliability you can depend on. The fact is they're simply built better.



Extra-Stability Stands with Oversized Base

MS20 / MS20E. Heavy-duty stands for studio, recording, church, and school application include an extra-height 1½" diameter tube assembly with wearproof clutch, top adapter, air suspension system, and low contour high-stability cast iron base. MS20 features chromed finish tube and ebony base. MS20E includes ebony finished tube and base.

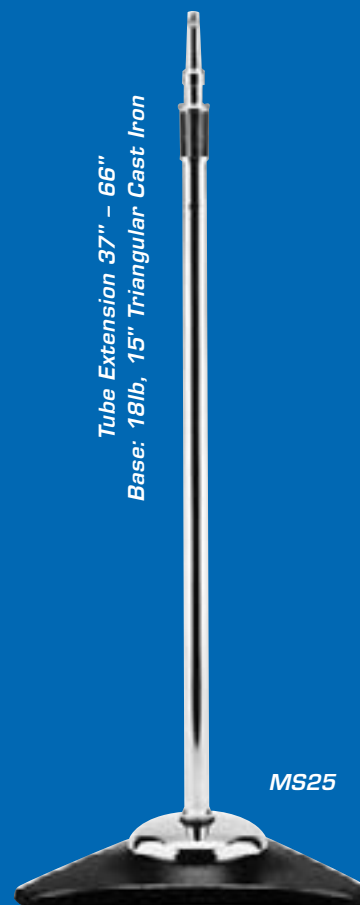

Studio Stands with Air Suspension System

MS25 / MS25E. Heavy-duty studio recording stand features 1½" diameter chromed tube assembly with integral air suspension system to protect sensitive microphones. Triangular cast base includes sculptured sides, ebony finish and decorative chrome cover.

Performer Series Boom Attachments

Performer Series booms are manufactured to the highest quality standards and combine exceptional styling with a unique, all-metal swivel clamp (US patent # 354,491) for greater user flexibility. **Clamp features Glide'n Position tubing with nylon brake bushings for smooth horizontal adjustment.** Resilient washers are made from compressed virgin wool fiber (in lieu of rubber) to offer quiet and secure positioning even after years of use. Extra-strength, steel T-bar knob assures no-fail locking with simple one-hand adjustment in the vertical plane. All versions include counterweights for increased balance and stability. All clamps are finished in non-reflective ebony epoxy. Tubing is manufactured of CRS and terminates in the standard $\frac{5}{8}$ " - 27 thread pattern.

Mini Adjustable Boom

PB11XCH / PB11XEB. Compact booms extend from 16 $\frac{1}{4}$ " to 24 $\frac{1}{2}$ " with a single motion—perfect for drum/piano/guitar amp and short distance miking. Units include a threaded end cap and a fixed $\frac{3}{4}$ lb counterweight for stability. Finish is chrome (CH) or ebony epoxy (EB) where noted.

Fixed-Length Booms

PB15CH / PB15EB. All-purpose, high-quality booms are 34" long and include fixed $\frac{3}{4}$ lb counterweights for stability. Select from chrome (CH) or ebony epoxy (EB) finish as noted.

Extendable-Length Booms

PB21XCH / PB21XEB. Booms extend from 25 $\frac{1}{4}$ " to 38 $\frac{1}{2}$ " with a single motion and are suitable for a wide variety of miking applications. Units contain a fixed $\frac{3}{4}$ lb counterweight and threaded end cap. Finish is chrome (CH) or ebony epoxy (EB) as noted.

General Purpose Boom

BE-E. This versatile, low-cost boom features adjustable-length positioning for extended mic range applications. The two-piece boom extends 24" - 39" and includes a molded plastic handle, metal swivel clamp with protective rubber insert, and an easy-grip knob for vertical alignment. Adjustment for the main and extension boom includes a thumbscrew /brake system to provide secure positioning and prevent tube marring. Tube assemblies are manufactured of CRS and terminate in standard $\frac{5}{8}$ " - 27 thread pattern. Satin ebony (E) finish. 2 lbs.

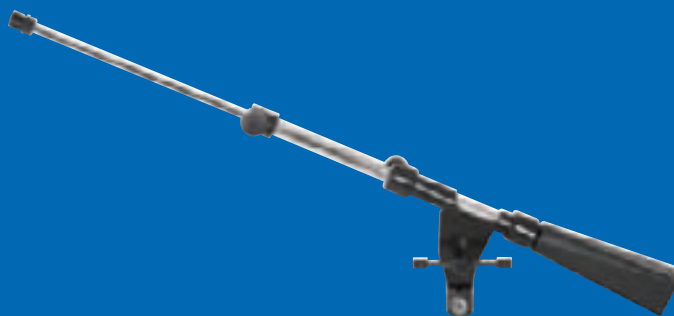

PB11XCH
Tube Extension 16 $\frac{1}{4}$ " - 24 $\frac{1}{2}$ "



PB15CH
Tube Length 34"



PB21XEB
Tube Extension 25 $\frac{1}{4}$ " - 38 $\frac{1}{2}$ "



BE-E
Tube Extension 24" - 39"



*Tube Extension 43" - 68"
Base: Xlb, xx" Stackable Cast Iron*

SB11WE

*Tube Extension 49" - 73"
Base: Xlb, xx" Stackable Cast Iron*

SB36W

Studio Boom Stands

Economical Studio Boom

SB11WE

Economical studio boom is especially suited for small studio/broadcast applications and for stage miking of drums and percussion instruments. Unit features a 60" L, two-piece horizontal boom assembly. Boom includes a Performer Series swivel clamp and an adjustable 2 lbs counterweight for effortless boom arm orientation. Tubing incorporates a 90° angled end for optimum microphone positioning and terminates in the standard $\frac{5}{8}$ " - 27 thread pattern. Stand features an Atlas Sound wearproof clutch for positive locking control. Triangular die-cast base offers extra stability and is equipped with hard rubber swivel casters for effortless and silent mobility. Finish is non-reflective ebony epoxy.

Professional Studio Boom with Air Suspension

SB36W / SB36WE

Heavy-duty stand for stage and studio applications include integral piston-type air suspension system for effortless height adjustment and microphone protection. Model is equipped with a two-piece horizontal chromed-tube assembly, adjustable 6 lbs boom counterweight, heavy-duty gyromatic swivel, Atlas Sound wearproof clutch and triangular cast iron base. SB Series include silent-motion, ball-bearing swivel casters of hard rubber for friction-free and vibration-absorbing mobility. Tubing terminates in the standard $\frac{5}{8}$ " - 27 thread pattern, and includes guide clips for microphone cable attachment. Tubing is finished in choice of chrome or ebony. Base is ebony epoxy with a chrome cover.



Vibration Isolating Stand

DS2. Low-silhouette stand features an integral tension mount to reduce conductivity of external mechanical vibrations. High-stability metal base with protective pads includes notched area for convenient placement of cards or pens. Fixed-height tubing is chrome finished. Base is ebony.



General Purpose Stands

DS5 / DS5E. Fixed-height stands include traditional, circular cast iron base and choice of tubing finish: chrome or ebony (E) as noted. Stands are suitable for application with any standard microphone.



Adjustable Stands

DS7 / DS7E. Versatile stands have a vertical height adjustment from 8" to 13" and include wearproof clutch and ebony finish cast iron base. DS7 features chromed tubing; DS7E has ebony tubing.



Contemporary Stand

DS14. Stand includes die-cast wishbone shaped base with ebony finish and fixed-height chrome tubing.

Stacking Stand

SMS5B

The most trusted name in microphone stands, Atlas Sound, is adding to its Atlas Support product line with new stacking mic stands. The SMS5B saves stage and storage space with its ability to stack as many as six units in a single 10" footprint. Now a single layer of microphone stands doesn't need to take up a separate storage room, and space on stage is freed up because of the compact base design.

Atlas Support stacking stands feature a wide mouth opening and floating pole design that through slight rotation can be easily stacked. The SMS5B comes in an anti reflective black finish and can be adjusted for 33' to 60.5" heights. It is the newest product in the full line of Atlas Support microphone and equipment stands by Atlas Sound, who over the past 70 years has been the one number name in microphone stands worldwide because of their performance and durability on stage and in studios worldwide.



MICCLIP

Industry standard microphone clip is made from rugged molded plastic; available in black the MICCLIP can accommodate microphones with a tapered diameter of 1" - 1½".



Microphone Stands

Economical Two-Piece Tripod & Tripod/Boom Stands

Atlas Sound's next generation of Musician Series tripods are lightweight, styled stands that offer the fit and feel of tripods costing considerably more.

TE-E

This is an all-purpose tripod. The full height stand extends from 37" to 65" and includes an all-new three-piece clutch design with a highly durable metal clutch barrel. Tripod legs attach to a metal retainer assembly that includes a thumbscrew / brake system to provide secure positioning and prevent tube marring. Tube assemblies are durable CRS construction terminated in the industry standard 5/8" - 27 thread pattern. Satin ebony (E) finish. 5½lbs

TEB-E

Tripod/boom combination features the BE-E removable, telescopic boom to provide microphone extension from 24" to 39". It includes a molded plastic handle, metal swivel clamp with protective rubber inserts and an easy-grip knob for vertical alignment. Adjustment for the main and extension boom include a thumbscrew/brake system to provide secure positioning and prevent tube marring. Tube assemblies are manufactured of CRS and terminate in the standard 5/8" - 27 thread pattern. Satin ebony (E) finish. 7½lbs

Instrument Miking Stands

DMS Series

Low-profile stands with high-stability cast base are ideal for professional drum miking applications. All feature adjustable-height tubing and the famous Atlas Sound clutch for precise orientation and a 10" diameter cast iron base for dependable positioning and isolation from drum vibrations. The DMS7(E) (C) combines a floor-stand base with desk-stand height—ideal for kick-drum miking. The DMS10(E)(C) is the taller version, ideal for miking toms and larger guitar amps. All include a threaded 5/8" tip assembly for compatibility with microphone clamps, goosenecks, and booms. (Mini-adjustable boom Models PB11X(E) are great companions.) Units are finished in ebony epoxy (E) where noted.



DMS7E
Tube Extension 8" - 13"
Base: 6lbs, 10" Round Cast Iron

DMS10E
Tube Extension 14½" - 26¼"
Base: 6lb, 10" Round Cast Iron



Tube Extension 37" - 65"
Base: Tripod

Tube Extension 24" - 39"
Base: Tripod

TE-E

TEB-E

Microphone Stands



*Speaker Not
Included*

SS500E

Lightweight Adjustable Stands

SS500E. Designed for easy transportability, set-up and tear down, the new heavy-duty SS500E aluminum speaker stand weighs a mere 7 lbs and supports up to 150 lbs! Additionally, the stand folds to a minimal 53" making it a great portable stand for use in churches, schools, and theaters. Height adjusts from 54" to 85" for versatile positioning and support of sound, monitor, and control equipment. The SS500E is equipped with a positive clamping system complete with a safety support pin to assure safe, slip-free support of elevated equipment. Vertical tube assembly contains 1½" and 1⅜" tubing. Clutch mechanism includes a protective insert for scratch-free height adjustment. Legs are double braced and include heavy-duty rubber feet for extra stability.

Top Adapters for Steel & Lightweight Stands

SSA7 Adapter for stand Model SS500E. It features a platform base with two ¾" x 2" equipment mounting slots and 4 holes to meet a variety of support applications.



SSA7

Mic Stand Accessories

Gooseneck Flexible Extensions

GN-6(E) / GN-13(E) / GN-19(E)

Flexible goosenecks in 6", 13", and 19" lengths attach to any mic stand or adapter with $\frac{5}{8}$ " - 27 male and female threads. Inside diameter is .338". Chrome or ebony (E) finish.



Clip-Mounting Microphone Accessories

LO-2B(E)

Lock-on accessory, respectively, allow fast connection and disconnection of plastic mic clamp holders and boom attachments with $\frac{5}{8}$ " - 27 threads for safe transportation. Available in chrome or ebony (E) where noted.

TM-1(E)

Versatile mic mount for live sound and stereo recording. Mounts two or three mics onto any stand. Unit is $8\frac{3}{4}$ " wide and fits mic clamps with $\frac{5}{8}$ " receptacles. Available in chrome or ebony (E).



Multi-Purpose Clamps

CO-1B

Connect-on swivel adapter/clamp provides for the addition of a second mic with standard $\frac{5}{8}$ " - 27 threads to any floor or desk stand with $\frac{5}{8}$ " or $\frac{7}{8}$ " diameter tubing. Ebony finish.

MAC-1

Multi-use adapter/clamp holds mics, booms, or accessories having $\frac{5}{8}$ " - 27 threads in vertical or horizontal orientation. Versatile unit also clamp mounts to $\frac{5}{8}$ ", $\frac{7}{8}$ ", and $1\frac{1}{8}$ " diameter tubing or to freestanding instruments, keyboards and drums. Made of high-strength extruded aluminum. Ebony finish. Weight: 1 $\frac{1}{2}$ lbs



Cable / Tambourine Hangers & Cable Feed-Thru Adapter

CH-1B(E)

Versatile accessory can be used to hang cabling or a tambourine. Single screw-mounting assembly fits all tube assembly sizes. Available in chrome or ebony (E).

AD-15B

Chrome 4" cable feed-thru adapter with standard $\frac{5}{8}$ " male and female threads.

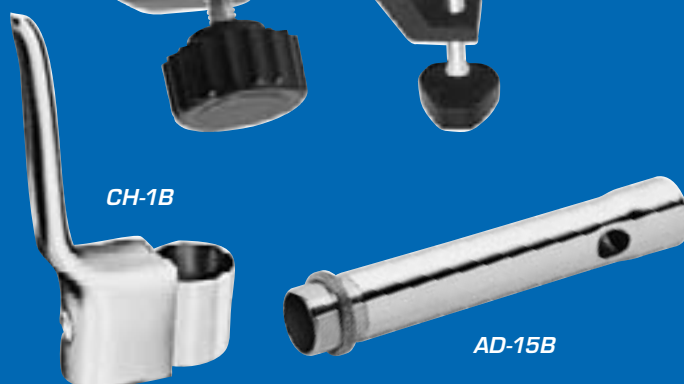

Couplings Used With Tube Extensions & Accessories

- AD-4B 3/4" long, 5/8" -27 male running thread; brass, no plating
- AD-5B 5/8" -27 female to 5/8" -27 female coupling; chrome plated
- AD-6B 7/8" female to 7/8" -27 female coupling; chrome plated

Surface-Mounting Fixtures

- AD-11B(E) 5/8" long, 5/8" -27 female flange with 1 3/4" base diameter; chrome or ebony (E)
- AD-12B(E) 5/8" long, 5/8" -27 male flange with 1 3/4" base diameter; chrome or ebony (E)
- AD-5B 5/8" -27 male flange with base holes on 1 1/4" centers; chrome or ebony (E)

Also available in 100 piece bulk pack. Specify AD-11(Chrome) or AD-1E(Ebony).

Tube Extensions Used With Coupling Adapters

- AD-7B 3" (76mm) long tube with 5/8" - 27 male at each end; chrome plated
- AD-8B 6" (152mm) long tube with 5/8" - 27 male at each end; chrome plated
- AD14B(E) Right angle tube with 5/8" - 27 male and female end; chrome plated; 4" (102mm) Height x 4" (102mm) Extension
- AD19B(E) 45° angle tube with 5/8" - 27 male and female end; chrome plated; 6" (152mm) Height x 3" (76mm) Extension



General Mic Stand Service Parts

- MSC-K Replacement Clutch Kit for 7/8" MS & DS Series – Chrome
- MSCE-K Replacement Clutch Kit for 7/8" MS & DS Series – Ebony
- MSC Complete Replacement Tube for MS-10C / MS-12C – Chrome
- MSCE Complete Replacement Tube for MS-10CE / MS-12CE – Ebony
- MS2025T Replacement Tube For MS20 / MS25 – Chrome
- MS2025TE Complete Replacement Tube for MS20E / MS25E – Ebony
- MS-20 B Replacement base for MS20
- MS20-K Replacement Clutch Kit for MS20 / MS25 Series – Chrome
- MS20E-K Replacement Clutch Kit for MS20E / MS25E Series – Ebony
- MS2XTA Replacement 7/8" - 5/8" Top Adapter for MS20 / MS25 – Chrome
- MS2XTAE Replacement 7/8" - 5/8" Top Adapter for MS20E / MS25E – Ebony
- PBB-K Replacement Boom Swivel Assembly for SB36 – Ebony
- SB36CSTR Replacement Caster Kit for SB36W (E) – Post 2004
- SB36WGHT Replacement Counterweight for SB36W(E)
- PB25WGHT Replacement Counterweight for PB11, PB15, PB21, & SB11WE
- XX4707700 Replacement Mic Swivel for SB36W (E)
- LR58E-25 Replacement 5/8" Lock Rings – Ebony –25 Piece Bag
- LR58C-25 Replacement 5/8" Lock Rings – Chrome –25 Piece Bag
- MS1012RF-24 Replacement Feet MS10 / MS12 – Pre 2003 – 24 Piece Bag
- MS12BASE Replacement Base for MS12
- XX8625000 Replacement 5/8" Phenolic Clutch Rings